

SAFETY & RELIEF VALVES

Multi-Purpose Safety Relief Valves

500 SERIES



Versatile safety relief valve available in bronze, carbon steel or all stainless steel construction, suitable for a wide range of steam, air, gas and liquid applications. High capacity full nozzle design is available with metal to metal, PCTFE or elastomer O-ring seating. Short tuned blowdown and backpressure tight body minimizes fugitive emissions and product losses in the event of valve operation.

ASME Section VIII Air, Steam, and Liquid service

Sizes 1/2" through 2" NPT

Factory set pressure range 5-1200 psig @ 800°F max.

(See press. / temp. limit chart below for specific ratings for each model).

APPLICATIONS:

- Pressure Vessels and Pressure Piping Systems
- Pumps, Tanks and Hydraulic Systems
- Thermal Relief of Liquid Filled Vessels
- Chemical, Process and other Industrial Plants.
- Power Plant Auxiliary Systems
- Cryogenic and Industrial Gases
- Air and Gas Compressors and Dryers
- Vacuum Relief



FEATURES:

- Wide Range of Materials and Options
- One Trim Design is Suitable for Steam, Air / Gas and Liquid Service
- High Capacity Full Nozzle Design
- Stainless Steel Springs
- Integral Lift Stop
- Self - Aligning Pivoting Disc
- API 527 Seat Tightness, standard for all models
- Tuned Blowdown - Short and Adjustable, reduces product losses.
- Backpressure Tight Design Minimizes Fugitive Emissions
- CSA B51 CRN OG8547.5C

OPTIONS:

- Screwed Cap (standard), Packed Lift Lever
- Test gags
- Elastomer or PCTFE Soft Seat for Exceptional Seat Tightness
- High Temperature Alloy Springs for 550°F - 800°F Service
- Special Cleaning Available
- European Pressure Equipment Directive compliant option (CE/PED)

HOW TO SELECT:

1. Determine the orifice letter that corresponds to your required flow rate from the capacity charts on pages 46-48.
2. Select the inlet x outlet connection options from the list of models available for that orifice from page 45.
3. Enter this base model number into the matrix below. Complete by specifying the Code, service and set pressure requirements.

500 SERIES MODEL NUMBERING SYSTEM

52	3	J	H	B	K	M	AA	0425	Q
SERIES BODY/ TRIM MATERIAL	CAP	ORIFICE LETTER	INLET SIZE	CONNECTION	SERVICE	SEAT	SPECIAL OPTIONS	SET PRESSURE	SUFFIX
51 = Bronze/Brass	1 = Screwed Cap	D	C = 1/2	B = MNPT x NPT	J = Sec VIII Liquid	M = Metal	Factory Issued	Set Pressure, PSIG	Q = Performance
52 = Bronze/Stainless	2 = Screwed + Gag	E	D = 3/4	D = 3/4 Outlet	K = Sec VIII Air/Gas	B = BUNA-N	Letters/Numbers for	(4 digits)	(Calibration)
53 = Carbon/Stainless	3 = Packed Lever	F	E = 1	(Model 510 &	L = Sec VIII Steam	E = EPR	Special Options or	Vacuum "HG"	Test Reports
54 = All Stainless	4 = Packed + Gag	G	F = 1-1/4	520 D Orifice Only)	M = Non Code Liquid	K = PCTFE	Features	Prefix + 2 digits	
		H	G = 1-1/2		N = Non Code Air	N = Neoprene	"AA" = Default Setting		
		J	H = 2		P = Non Code Steam	Z = Kalrez®	"CE" = CE/PED		
					Q = Vacuum	S = Silicone	"HT" = High Temp Spring		
						V = Viton	"OX" = Cleaned for Oxygen		

Notes:

1. The ASME Code Section VIII requires a lift lever for the following services: air, steam, or hot water over 140°F
2. Maximum back pressure is 50 psig.
3. High temperature stainless steel alloy spring is required above 550°F / 288°C. Specify option "HT"
4. Contact factory for pricing and availability.



For additional information, submittal sheets and manuals, visit www.apollovalves.com

Customer Service (704) 841-6000

SAFETY & RELIEF VALVES

Multi-Purpose Safety Relief Valves

500 SERIES

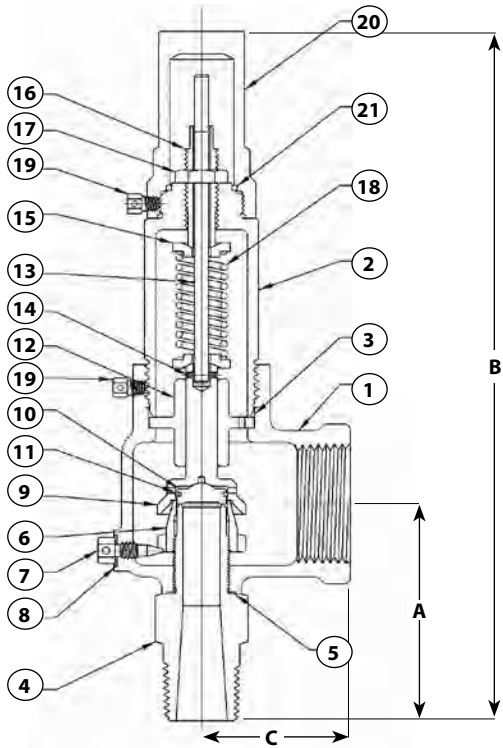

500 ASSEMBLY W/SCREWED CAP

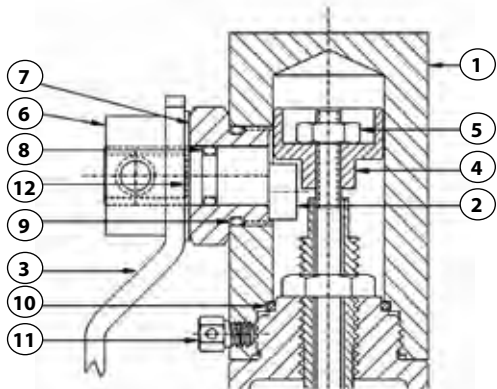

PACKED LEVER DETAIL

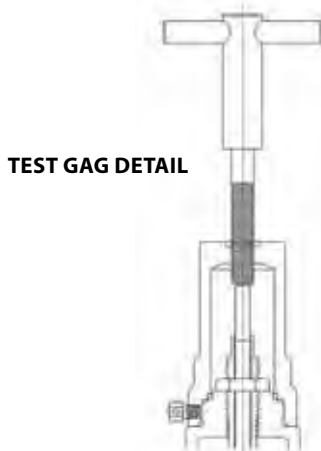

TEST GAG DETAIL

MATERIALS

Item	Component	Material 510 Series	Material 520 Series	Material 530 Series	Material 540 Series
1	Body	Bronze B-584-C844	Bronze B-584-C844	Steel SA-216 WCB	SS SA-351-CF8M
2	Bonnet	Brass*	Brass*	Steel**	SS Type 316***
3	Bonnet Seal	PTFE	PTFE	PTFE	PTFE
4	Nozzle	Brass B-16	SS Type 316	SS Type 316	SS Type 316
5	Nozzle Seal	PTFE	PTFE	PTFE	PTFE
6	Nozzle Ring	SS Type 316	SS Type 316	SS Type 316	SS Type 316
7	Set Screw	Brass	Brass	SS Type 316	SS Type 316
8	Set Screw Seal	PTFE	PTFE	PTFE	PTFE
9	Disc Holder	Brass	SS Type 316	SS Type 316	SS Type 316
10	Disc	SS Type 316	SS type 316	SS Type 316	SS Type 316
11	Retaining Ring	Stainless Steel	Stainless Steel	Stainless Steel	Stainless Steel
12	Disc Guide	Brass	Brass	SS Type 316	SS Type 316
13	Stem	Brass	Brass	SS Type 316	SS Type 316
14	Spring Pin	Stainless Steel	Stainless Steel	Stainless Steel	Stainless Steel
15	Spring Washer	Brass	Brass	SS Type 316	SS Type 316
16	Adjusting Bolt	Brass	Brass	SS Type 316	SS Type 316
17	Lock nut	Brass	Brass	SS Type 316	SS Type 316
18	Spring	Stainless Steel	Stainless Steel	Stainless Steel	Stainless Steel
	Spring, High Temp.	Inconel	Inconel	Inconel	Inconel
19	Lock Screw	Stainless Steel	Stainless Steel	Stainless Steel	Stainless Steel
20	Cap, Screwed	Brass	Brass	Steel	SS Type 316
21	Seal, Cap	Viton	Viton	Viton	Viton
-	Nameplate	Stainless Steel	Stainless Steel	Stainless Steel	Stainless Steel
-	Drive Screw	Stainless Steel	Stainless Steel	Stainless Steel	Stainless Steel
-	Seal & Wire	Lead/SS	Lead/SS	Lead/SS	Lead/SS
-	Seal & Wire (CE)			Alum/SS	Alum/SS

Notes:

* Sizes G, H and J are Cast Bronze

** Sizes H and J are Cast Steel

*** Sizes H and J are Cast Stainless Steel Type 316

MATERIALS, LIFT LEVER OPTION

Item	Component	Material 513, 523 Series	Material 533 Series	Material 543 Series
1	Cap, Packed Lever	Brass	Steel	SS Type 316
2	Cam Bushing	Stainless Steel	Stainless Steel	Stainless Steel
3	Lever	Stainless Steel	Stainless Steel	Stainless Steel
4	Lift Washer	Stainless Steel	Stainless Steel	Stainless Steel
5	Locknut	Stainless Steel	Stainless Steel	Stainless Steel
6	Collar	Stainless Steel	Stainless Steel	Stainless Steel
7	Cam Bushing	Brass	Stainless Steel	Stainless Steel
8	Cam O-Ring	Viton	Viton	Viton
9	Bushing O-Ring	Viton	Viton	Viton
10	Seal, Cap	Viton	Viton	Viton
11	Set Screw	Stainless Steel	Stainless Steel	Stainless Steel
12	Washer	PTFE	PTFE	PTFE

500 SERIES SOFT SEAT DETAIL

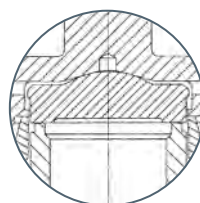

PCTFE

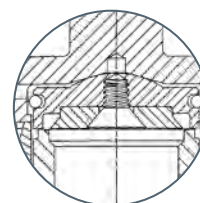

O-RING

www.apollovalves.com

Customer Service (704) 841-6000



SAFETY & RELIEF VALVES

Multi-Purpose Safety Relief Valves

500 SERIES

Soft Seat Pressure & Temperature Limits* - 500 Series

Seat Material	Set Pressure		Temperature		Service Recommendations**
	Min.	Max.	Min.	Max.	
Viton	15	900	-15°F	400°F	Air, Benzene, Butane, Carbon Dioxide, Carbon Disulphide, Carbon Tetrachloride, Dowtherm A, Ethyl Alcohol, Ethyl Chloride, Ethylene, Ethylene Glycol, Fuel Oil, Gasoline, Hydraulic Fluid, JP-4 and -5 Fuel, Kerosene, Lube Oil, Natural Gas, Naphtha, Nitrogen, Propane, Propyl Alcohol, Propylene, Propylene Glycol, Sulphur Dioxide, Toluene, Trichlorethylene, Turpentine, Vinyl Chloride, Water
EPDM	15	900	-70°F	250°F	Steam, Water, Hot Water, Acetone, Beer, Brake Fluid, Hydrogen Gas, Hydrogen Sulphide, Phosphate Ester Hydraulic Fluid, Sulphur Dioxide, Acids, Alkalis
Silicone	15	900	-60°F	450°F	Air, Helium, Nitrogen, Oxygen (gaseous)
Neoprene	15	900	-35°F	225°F	Air, Anhydrous Ammonia, Butane, Butyl Alcohol, Castor Oil, Denatured Alcohol, Ethanol, Ethyl Alcohol, Freon 12, 13, 14 & 22, Glycols, Natural Gas, Oxygen (gaseous), Silicate Esters
Nitrile / Buna-N	15	900	-30°F	250°F	Air, Anhydrous Ammonia, Butane, Carbon Dioxide, Diesel Oil, Freon 11 & 12, Fuel Oil, Gasoline, Helium, Hydraulic Fluid (petroleum based), Hydrogen Sulphide, Hydrogen Gas, Kerosene, Lube Oil, Natural Gas, Nitrogen, Oxygen (gaseous), Propane, Propylene, Sulphur Dioxide, Vinyl Chloride
PCTFE	15	500	-320°F	250°F	Cryogenic Service including Argon, Carbon Dioxide, Helium, Hydrogen, Nitrogen, Oxygen

Notes:

* Subject to valve body material pressure / temperature limitations. See chart below.

** Service recommendations are provided for guidance only. Material suitability and selection should be determined by the end user based on their prior experience with the service and materials involved.

PRESSURE AND TEMPERATURE RATINGS

Series Body Trim	510 Bronze Brass	520 Bronze Stainless	530 Carbon Steel Stainless	540 Stainless Steel Stainless
Max. Set- Steam	250 PSI	300 PSI	900 PSI (D/E) 600 PSI (F/G) 500 PSI (H/J)	900 PSI (D/E) 600 PSI (F/G) 500 PSI (H/J)
Max. Set- Air/Gas/ Liquid	300 PSI	1200 PSI (D) ¹ 900 PSI (E) 600 PSI (F/G) 500 PSI (H/J)	1200 PSI (D) ¹ 900 PSI (E) 600 PSI (F/G) 500 PSI (H/J)	1200 PSI (D) ¹ 900 PSI (E) 600 PSI (F/G) 500 PSI (H/J)
Temp. Limits*	-320/406°F	-320/422°F	-20/800°F	-320/800°F

¹Max set pressure for liquids is 1000 psi.

Notes:

- Limits based upon materials of construction and use of metal to metal seating. Refer to 500 series soft seat chart for limitations based upon elastomer.
- Specify "HT" high temperature Inconel springs for service temperature beyond 422°F.
- Models 510, 520 and 540 are suitable for cryogenic service to -320°F, with choice of either "M" metal or "K" PCTFE seat options.

DIMENSIONS AND WEIGHTS

Model Number	Orifice Letter	Size Inlet x Outlet	Dimensions (in./mm.)			Weight (Lb./kg.)
			A	B	C	
5xxDC	D	1/2 X 1	2.38	7.5	1.63	2
			60	191	41	0.9
5xxDCD*	D	1/2 X 3/4	2.38	7.5	1.63	2
			60	191	41	0.9
5xxDD	D	3/4 X 1	2.38	7.5	1.63	2
			60	191	41	0.9
5xxDDD*	D	3/4 X 3/4	2.38	7.5	1.63	2
			60	191	41	0.9
5xxED	E	3/4 X 1-1/4	2.63	9	2	3
			67	229	51	1.4
5xxEE	E	1 X 1-1/4	2.63	9	2	3
			67	229	51	1.4
5xxFE	F	1 X 1-1/2	2.83	10.25	2.38	5
			73	260	60	2.3
5xxFF	F	1-1/4 X 1-1/2	2.83	10.25	2.38	5
			73	260	60	2.3
5xxGF	G	1-1/4 X 2	3.25	13.25	2.63	9
			83	337	67	4.1
5xxGG	G	1-1/2 X 2	3.25	13.25	2.68	9.5
			83	337	67	4.31
5xxHG	H	1-1/2 X 2-1/2	3.5	15	2.75	15.5
			89	381	70	7.0
5xxHH	H	2 X 2-1/2	3.5	15	2.75	16
			89	381	70	7.3
5xxJH	J	2 X 3	4	17	3.25	24
			102	432	83	10.9

* 3/4" Outlet option available with 510 and 520 bronze bodied models only.



For additional information, submittal sheets and manuals, visit www.apollovalves.com

Customer Service (704) 841-6000

SAFETY & RELIEF VALVES



Multi-Purpose Safety Relief Valves

500 SERIES

ASME SECTION VIII STEAM

Pounds per hour (Kilograms per hour) saturated steam at 10% overpressure. National Board Certified. Ratings are 90% of actual.

US Customary Units Lbs./Hr.

Metric Units Kg./Hr.

Orifice Letter Area (in. ²)	D 0.1295	E 0.2282	F 0.3589	G 0.5890	H 0.9195	J 1.5044	Orifice Letter Area (cm. ²)	D 0.8352	E 1.4721	F 2.3155	G 3.8001	H 5.9321	J 9.7058						
Set Pressure psig							Set Pressure barg												
5*	122	216	339	557	869	1,422	0.4*	60	105	165	271	423	692						
10*	168	295	465	762	1,190	1,947	0.8*	82	145	228	374	583	955						
15	188	331	520	853	1,332	2,180	1.1	88	154	243	398	622	1,018						
20	216	381	600	984	1,536	2,513	2	122	214	337	553	863	1,412						
25	245	432	679	1,114	1,740	2,846	3	163	287	451	741	1,156	1,892						
30	274	482	759	1,245	1,943	3,180	4	204	360	566	930	1,451	2,374						
35	305	538	846	1,388	2,168	3,546	5	246	433	681	1,118	1,746	2,857						
40	337	593	934	1,532	2,392	3,913	6	287	506	797	1,307	2,041	3,339						
45	368	649	1,021	1,676	2,616	4,280	7	329	580	912	1,496	2,336	3,821						
50	400	705	1,108	1,819	2,840	4,646	8	370	653	1,027	1,685	2,630	4,304						
55	431	760	1,196	1,963	3,064	5,013	9	412	726	1,142	1,874	2,925	4,786						
60	463	816	1,283	2,106	3,288	5,380	10	453	799	1,257	2,063	3,220	5,269						
65	494	872	1,371	2,250	3,512	5,746	12	536	945	1,487	2,441	3,810	6,233						
70	526	927	1,458	2,393	3,736	6,113	14	619	1,092	1,717	2,818	4,400	7,198						
75	558	983	1,546	2,537	3,960	6,479	16	702	1,238	1,947	3,196	4,989	8,163						
80	589	1,038	1,633	2,680	4,184	6,846	18	786	1,384	2,178	3,574	5,579	9,128						
85	621	1,094	1,721	2,824	4,408	7,213	20	869	1,531	2,408	3,952	6,169	10,093						
90	652	1,150	1,808	2,968	4,632	7,579	22	952	1,677	2,638	4,329	6,758	11,058						
95	684	1,205	1,896	3,111	4,857	7,946	24	1,035	1,823	2,868	4,707	7,348	12,022						
100	715	1,261	1,983	3,255	5,081	8,313	26	1,118	1,970	3,098	5,085	7,938	12,987						
125	873	1,539	2,421	3,972	6,201	10,146	28	1,201	2,116	3,329	5,463	8,527	13,952						
150	1,031	1,817	2,858	4,690	7,322	11,979	30	1,284	2,262	3,559	5,840	9,117	14,917						
175	1,189	2,095	3,295	5,408	8,442	13,812	32	1,367	2,409	3,789	6,218	9,707	15,882						
200	1,346	2,373	3,733	6,126	9,562	15,645	34	1,450	2,555	4,019	6,596	10,297	16,846						
225	1,504	2,651	4,170	6,843	10,683	17,478	36	1,533	2,701	4,249	6,974	-	-						
250	1,662	2,929	4,607	7,561	11,803	19,312	38	1,616	2,848	4,479	7,351	-	-						
275	1,820	3,207	5,045	8,279	12,924	21,145	40	1,699	2,994	4,710	7,729	-	-						
300	1,977	3,485	5,482	8,997	14,044	22,978	42	1,782	3,140	-	-	-	-						
325	2,135	3,763	5,919	9,714	15,165	24,811	44	1,865	3,287	-	-	-	-						
350	2,293	4,041	6,357	10,432	16,285	26,644	46	1,948	3,433	-	-	-	-						
375	2,451	4,319	6,794	11,150	17,405	28,477	48	2,031	3,579	-	-	-	-						
400	2,608	4,597	7,231	11,867	18,526	30,311	50	2,114	3,726	-	-	-	-						
425	2,766	4,875	7,669	12,585	19,646	32,144	52	2,197	3,872	-	-	-	-						
450	2,924	5,153	8,106	13,303	20,767	33,977	54	2,280	4,019	-	-	-	-						
475	3,082	5,431	8,543	14,021	21,887	35,810	58	2,446	4,311	-	-	-	-						
500	3,239	5,709	8,981	14,738	23,008	37,643	62	2,612	4,604	-	-	-	-						
525	3,397	5,987	9,418	15,456	-	-	65	2,736	-	-	-	-	-						
550	3,555	6,266	9,855	16,174	-	-	69	2,902	-	-	-	-	-						
575	3,713	6,544	10,293	16,892	-	-	72	3,026	-	-	-	-	-						
600	3,870	6,822	10,730	17,609	-	-	76	3,192	-	-	-	-	-						
625	4,028	7,100	-	-	-	-	79	3,316	-	-	-	-	-						
650	4,186	7,378	-	-	-	-	82	3,441	-	-	-	-	-						
675	4,344	7,656	-	-	-	-	Approx. 0.1 bar Increment												
700	4,501	7,934	-	-	-	-													
725	4,659	8,212	-	-	-	-	4.15	7.32	11.51	18.89	29.48	48.24							
750	4,817	8,490	-	-	-	-	Maximum Set Pressure Limits for Steam Service 510 Series - 250 psig/17.3 barg 520 Series - 300 psig/20.7 barg 530 Series - 900 psig/62.1 barg 540 Series - 900 psig/62.1 barg Note: For steam service beyond 300 psig or 550°F specify option "HT" high temperature stainless steel alloy spring. *Pressure settings below 15 psig/1.03 barg are non-ASME code.												
775	4,975	8,768	-	-	-	-													
800	5,132	9,046	-	-	-	-													
825	5,290	9,324	-	-	-	-													
850	5,448	9,602	-	-	-	-													
875	5,606	9,880	-	-	-	-													
900	5,763	10,158	-	-	-	-													
Approx. 1 psi Increment														6.3	11.1	17.5	28.7	44.8	73.3

Maximum Set Pressure Limits for Steam Service

- 510 Series - 250 psig/17.3 barg
- 520 Series - 300 psig/20.7 barg
- 530 Series - 900 psig/62.1 barg
- 540 Series - 900 psig/62.1 barg

Note: For steam service beyond 300 psig or 550°F specify option "HT" high temperature stainless steel alloy spring.

*Pressure settings below 15 psig/1.03 barg are non-ASME code.

SAFETY & RELIEF VALVES

Multi-Purpose Safety Relief Valves



500 SERIES

ASME SECTION VIII AIR

Standard cubic feet per minute (Normalized cubic meters per hour) of air at 10% overpressure. National Board Certified. Ratings are 90% of actual.

US Customary Units SCFM

Metric Units Nm³/Hr.

Orifice Letter Area (in. ²)	D 0.1295	E 0.2282	F 0.3589	G 0.5890	H 0.9195	J 1.5044	Orifice Letter Area (cm ²)	D 0.8352	E 1.4721	F 2.3155	G 3.8001	H 5.9321	J 9.7058
Set Pressure psig							Set Pressure barg						
5*	39	69	108	178	277	454	0.4*	67	119	187	307	479	784
10*	54	96	151	248	387	633	0.8*	94	165	260	427	667	1,091
15	67	118	185	304	474	776	1.1	110	195	306	503	784	1,283
20	77	136	213	350	547	895	2	153	270	425	697	1,089	1,781
25	87	154	242	397	619	1,013	3	205	362	569	934	1,458	2,386
30	97	172	270	443	692	1,132	4	258	454	714	1,172	1,830	2,994
35	109	191	301	494	772	1,262	5	310	546	859	1,411	2,202	3,603
40	120	211	332	545	851	1,393	6	362	639	1,005	1,649	2,574	4,211
45	131	231	363	596	931	1,523	7	415	731	1,150	1,887	2,946	4,819
50	142	251	395	648	1,011	1,654	8	467	823	1,295	2,125	3,317	5,428
55	154	271	426	699	1,091	1,784	9	519	916	1,440	2,363	3,689	6,036
60	165	290	457	750	1,170	1,915	10	572	1,008	1,585	2,601	4,061	6,644
65	176	310	488	801	1,250	2,045	12	676	1,192	1,875	3,078	4,805	7,861
70	187	330	519	852	1,330	2,176	14	781	1,377	2,166	3,554	5,548	9,078
75	198	350	550	903	1,410	2,306	16	886	1,561	2,456	4,031	6,292	10,295
80	210	370	581	954	1,489	2,437	18	991	1,746	2,746	4,507	7,036	11,511
85	221	389	612	1,005	1,569	2,567	20	1,095	1,931	3,037	4,983	7,779	12,728
90	232	409	644	1,056	1,649	2,698	22	1,200	2,115	3,327	5,460	8,523	13,945
95	243	429	675	1,107	1,729	2,828	24	1,305	2,300	3,617	5,936	9,267	15,162
100	255	449	706	1,158	1,808	2,959	26	1,409	2,484	3,907	6,413	10,010	16,378
125	311	548	862	1,414	2,207	3,611	28	1,514	2,669	4,198	6,889	10,754	17,595
150	367	647	1,017	1,669	2,606	4,264	30	1,619	2,853	4,488	7,365	11,498	18,812
175	423	746	1,173	1,925	3,005	4,916	32	1,724	3,038	4,778	7,842	12,241	20,029
200	479	845	1,329	2,180	3,404	5,569	34	1,828	3,222	5,069	8,318	12,985	21,245
225	535	944	1,484	2,436	3,802	6,221	36	1,933	3,407	5,359	8,795	-	-
250	592	1,043	1,640	2,691	4,201	6,874	38	2,038	3,591	5,649	9,271	-	-
275	648	1,142	1,796	2,947	4,600	7,526	40	2,142	3,776	5,939	9,747	-	-
300	704	1,240	1,951	3,202	4,999	8,179	42	2,247	3,961	-	-	-	-
325	760	1,339	2,107	3,458	5,398	8,831	44	2,352	4,145	-	-	-	-
350	816	1,438	2,263	3,713	5,796	9,484	46	2,457	4,330	-	-	-	-
375	872	1,537	2,418	3,969	6,195	10,136	48	2,561	4,514	-	-	-	-
400	928	1,636	2,574	4,224	6,594	10,789	50	2,666	4,699	-	-	-	-
425	985	1,735	2,730	4,480	6,993	11,441	52	2,771	4,883	-	-	-	-
450	1,041	1,834	2,885	4,735	7,392	12,094	54	2,875	5,068	-	-	-	-
475	1,097	1,933	3,041	4,991	7,791	12,746	58	3,085	5,437	-	-	-	-
500	1,153	2,032	3,197	5,246	8,189	13,399	62	3,294	5,806	-	-	-	-
525	1,209	2,131	3,352	5,501	-	-	65	3,450	-	-	-	-	-
550	1,265	2,230	3,508	5,757	-	-	69	3,659	-	-	-	-	-
575	1,321	2,329	3,664	6,012	-	-	72	3,815	-	-	-	-	-
600	1,378	2,428	3,819	6,268	-	-	76	4,020	-	-	-	-	-
625	1,434	2,527	-	-	-	-	79	4,177	-	-	-	-	-
650	1,490	2,626	-	-	-	-	82	4,381	-	-	-	-	-
675	1,546	2,725	-	-	-	-	Approx. 0.1 bar Increment						
700	1,602	2,824	-	-	-	-	5.24	9.23	14.51	23.82	37.18	60.84	
725	1,658	2,923	-	-	-	-							
750	1,715	3,022	-	-	-	-							
775	1,771	3,121	-	-	-	-							
800	1,827	3,220	-	-	-	-							
825	1,883	3,319	-	-	-	-							
850	1,939	3,418	-	-	-	-							
875	1,995	3,517	-	-	-	-							
900	2,051	3,616											
950	2,163	-	-	-	-	-							
1000	2,276	-	-	-	-	-							
1050	2,388	-	-	-	-	-							
1100	2,501	-	-	-	-	-							
1150	2,613	-	-	-	-	-							
1200	2,725	-	-	-	-	-							
Approx. 1 psi Increment	2.2	4.0	6.2	10.2	16.0	26.1							

Maximum Set Pressure Limits for Air/Gas Service

- 510 Series - 300 psig/20.7 barg
- 520 Series - 1200 psig/82.7 barg
- 530 Series - 1200 psig/82.7 barg
- 540 Series - 1200 psig/82.7 barg

*Pressure settings below 15 psig/1.03 barg are non-ASME code.



For additional information, submittal sheets and manuals, visit www.apollovalves.com

Customer Service (704) 841-6000

SAFETY & RELIEF VALVES



Multi-Purpose Safety Relief Valves

500 SERIES

ASME SECTION VIII WATER

U.S. gallons per minute (Cubic meters per hour) of water at 10% over pressure. National Board Certified. Ratings are 90% of actual.

US Customary Units GPM

Metric Units M³/Hr.

Orifice Letter Area (in. ²)	D 0.1295	E 0.2282	F 0.3589	G 0.5890	H 0.9195	J 1.5044	Orifice Letter Area (cm ²)	D 0.8352	E 1.4721	F 2.3155	G 3.8001	H 5.9321	J 9.7058
Set Pressure psig							Set Pressure barg						
5*	13	24	37	61	95	156	0.4*	2.0	3.6	5.6	9.2	14.4	23.6
10*	14	24	38	63	98	161	0.8*	2.9	5.1	8.0	13.1	20.4	33.3
15	14	25	40	65	102	167	1.1	3.3	5.9	9.3	15.2	23.8	38.9
20	16	29	45	74	115	189	2	4.4	7.7	12.1	19.8	30.9	50.6
25	18	32	50	82	127	208	3	5.3	9.4	14.8	24.2	37.8	61.8
30	19	34	54	89	138	226	4	6.1	10.8	17.0	28.0	43.6	71.4
35	21	37	58	96	149	244	5	6.9	12.1	19.0	31.3	48.8	79.8
40	22	40	62	102	160	261	6	7.5	13.3	20.9	34.2	53.4	87.4
45	24	42	66	108	169	277	7	8.1	14.3	22.5	37.0	57.7	94.5
50	25	44	70	114	178	292	8	8.7	15.3	24.1	39.5	61.7	101.0
55	26	46	73	120	187	306	9	9.2	16.2	25.6	41.9	65.5	107.1
60	28	48	76	125	195	320	10	9.7	17.1	26.9	44.2	69.0	112.9
65	29	50	79	130	203	333	12	10.6	18.8	29.5	48.4	75.6	123.7
70	30	52	82	135	211	345	14	11.5	20.3	31.9	52.3	81.6	133.6
75	31	54	85	140	218	357	16	12.3	21.7	34.1	55.9	87.3	142.8
80	32	56	88	145	226	369	18	13.0	23.0	36.1	59.3	92.6	151.5
85	33	58	91	149	233	381	20	13.7	24.2	38.1	62.5	97.6	159.7
90	34	59	93	153	239	392	22	14.4	25.4	39.9	65.6	102.3	167.5
95	35	61	96	158	246	402	24	15.1	26.5	41.7	68.5	106.9	174.9
100	36	63	98	162	252	413	26	15.7	27.6	43.4	71.3	111.3	182.0
125	40	70	110	181	282	462	28	16.3	28.7	45.1	74.0	115.5	188.9
150	44	77	121	198	309	506	30	16.8	29.7	46.7	76.6	119.5	195.5
175	47	83	130	214	334	546	32	17.4	30.6	48.2	79.1	123.4	202.0
200	50	89	139	229	357	584	34	17.9	31.6	49.7	81.5	127.2	208.2
225	53	94	148	242	378	619	36	18.4	32.5	51.1	83.9	-	-
250	56	99	156	256	399	653	38	18.9	33.4	52.5	86.2	-	-
275	59	104	163	268	418	685	40	19.4	34.2	53.9	88.4	-	-
300	62	108	171	280	437	715	42	19.9	35.1	-	-	-	-
325	64	113	178	291	455	744	44	20.4	35.9	-	-	-	-
350	66	117	184	302	472	772	46	20.8	36.7	-	-	-	-
375	69	121	191	313	489	799	48	21.3	37.5	-	-	-	-
400	71	125	197	323	505	826	50	21.7	38.3	-	-	-	-
425	73	129	203	333	520	851	52	22.2	39.0	-	-	-	-
450	75	133	209	343	535	876	54	22.6	39.8	-	-	-	-
475	77	136	215	352	550	900	58	23.4	41.2	-	-	-	-
500	79	140	220	361	564	923	62	24.2	42.6	-	-	-	-
525	81	143	226	370	-	-	65	24.8	-	-	-	-	-
550	83	147	231	379	-	-	69	25.6	-	-	-	-	-
575	85	150	236	388	-	-							
600	87	153	241	396	-	-							
625	89	157	-	-	-	-							
650	91	160	-	-	-	-							
675	92	163	-	-	-	-							
700	94	166	-	-	-	-							
725	96	169	-	-	-	-							
750	97	171	-	-	-	-							
775	99	174	-	-	-	-							
800	100	177	-	-	-	-							
825	102	180	-	-	-	-							
850	104	183	-	-	-	-							
875	105	185	-	-	-	-							
900	107	188	-	-	-	-							
950	109	-	-	-	-	-							
1000	112	-	-	-	-	-							

Maximum Set Pressure Limits for Liquid Service

- 510 Series - 300 psig/20.7 barg
- 520 Series - 1000 psig/68.9 barg
- 530 Series - 1000 psig/68.9 barg
- 540 Series - 1000 psig/68.9 barg

Note: To determine water capacity at 25% overpressure, multiply the capacity at 10% by 1.066.

*Pressure settings below 15 psig/1.03 barg are non-ASME code.